

Round, Semi-Tubular Rivet

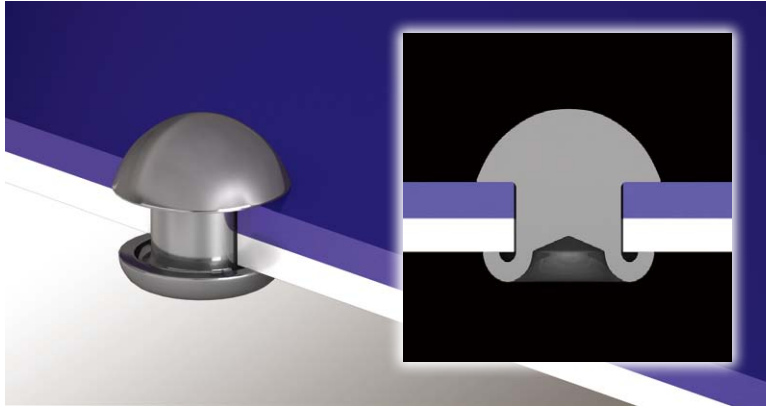

Shape and symbols of standard dimensions

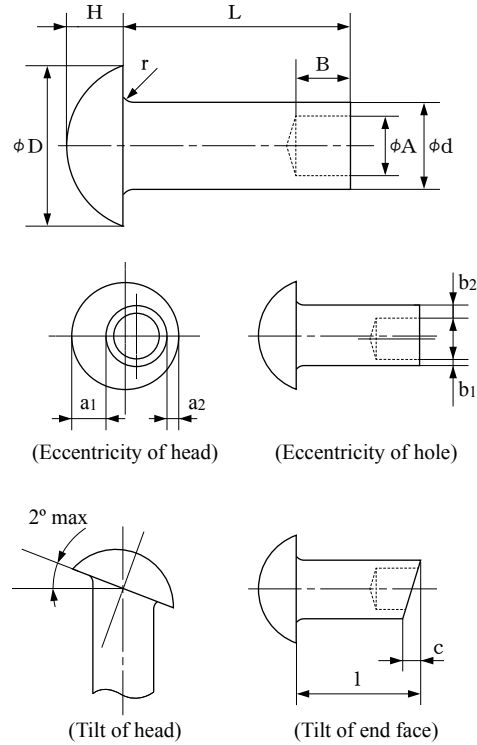

Calculation of under-head shank length

Material thickness t ^{*3}
 $L = \frac{\text{Shank diameter}(d) \times \text{Coefficient}(0.6) + \text{Material thickness}(t)}{1}$ ^{*2}

Shank diameter d
 Swaging margin K
 Under-head shank length L

*1. Shank diameter (d) x 0.6 = swaging margin (K)
 *2. Use coefficient (0.5) as a guide for SUSXM7 (with hole diameter/depth between 0.75 d and 0.77 d)
 *3. The under-head shank length L should be less than 5 times the shank diameter or in the case of stainless steel less than double.
 [When a length exceeding the specification is required, please ask us.]

The length obtained by this calculation shall be used as a guide.

Specification table

Nominal diameter		1.2	1.6	2	2.5	3	4	5	6	8	
d	Standard	1.2	1.6	2	2.5	3	4	5	6	8	
	Tolerance	+0.02 -0.05			0 -0.08		0 -0.10		0 -0.12	0 -0.15	
D	Standard	2.2	3	3.7	4.6	5.4	7.2	9	10.5	13.5	
	Tolerance	0 -0.3				0 -0.4		0 -0.5	0 -0.6		
H	Standard	0.7	1	1.2	1.5	1.8	2.4	3	3.6	4.8	
	Tolerance	±0.05				±0.1					
A	Standard	0.8	1.1	1.3	1.7	2.1	2.8	3.5	4.2	5.6	
	Tolerance	±0.04		±0.05		±0.07		±0.10			
B	Standard	1.1	1.4	1.8	2.3 ^{*4}	2.7 ^{*4}	3.6 ^{*4}	4.5 ^{*4}	5.4	7.2	
	Tolerance	±0.1		±0.15		±0.2		±0.25	±0.3		
r	Max	0.06	0.08	0.1	0.2		0.3		0.4		
a1-a2	Max	0.1	0.2				0.3		0.4		
b1-b2	Max	0.1			0.15			0.2			
c	Max	0.2			0.3		0.4			0.5	
L	Min	2	2.5	3	3	3.5	4.5	6	8	10	
	Max	10	14	14	20	22	28	36	42	56	
Recommended work hole diameter	Standard	1.25	1.65	2.1	2.65	3.15	4.2	5.3	6.4	8.5	
	Tolerance	+0.05 0				±0.05				±0.10	

*4. When length L is close to the minimum or maximum, length B shall be $0.8 \times d$. For details, see the length B list below.

Tolerance of length L

Nominal diameter		1.2	1.6	2	2.5	3	4	5	6	8
Length L	4 or below	±0.1		±0.15		—				
	Over 4 to 10	±0.15		±0.2		±0.25				
	Over 10 to 20	±0.2		±0.25		±0.3				
	Over 20 to 40	—		±0.3		±0.4				
	Over 40	—		—		±0.5				

Length B list

Nominal diameter	2.5	3	4	5	
Length L	3 3.5	3.5 4.5	4.5 5	5 5.5	
Length B	2.0	2.4	3.2		4.0

Name

Low round Semi-tubular 3 × 5

- ① Type of head (Low round, truss, flat, countersunk and round)
 ② Rivet type (Semi-tubular)
 ③ Nominal diameter (See the specification table.)
 ④ Under-head shank length (See the specification table.)

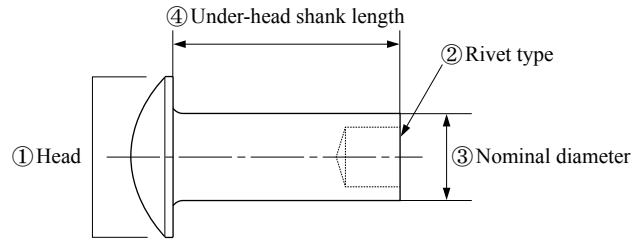

Types of heads

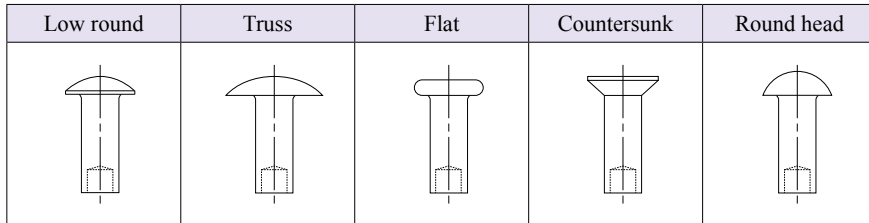

Rivet type

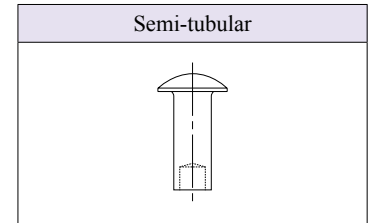

Types of materials and relevant JIS

Materials			Relevant JIS
Description	Code		
Iron	Carbon steel wire	SWCH	JIS G 3507 "Carbon steels for cold heading"
Brass	Brass wire	C2700W	JIS H 3260 "Copper and copper alloy wires"
Copper	Tough pitch copper wire	C1100W	
Aluminum	Aluminum drawn wire	A1070W	JIS H 4040 "Aluminum or aluminum alloy wire"
		A1200W	
	Aluminum alloy drawn wire	A5052W	
		A5056W	
Stainless steel	Stainless steel wire	SUS430-WR	JIS G 4308 "Stainless steel wire"
		SUSXM7-WR	

Strength test results by material and shank diameter

Nominal diameter		φ1.2	φ1.6	φ2	φ2.5	φ3	φ4	φ5	φ6	φ8	Unit (kN)
Material	SWCH10A	Tensile	0.29	0.49	0.85	1.23	1.69	3.00	4.69	6.76	12.02
		Shear	0.34	0.61	0.96	1.50	2.17	3.86	6.03	8.68	15.43
	SUS430	Tensile	0.39	0.66	1.14	1.66	2.27	4.03	6.31	9.08	16.15
		Shear	0.45	0.80	1.26	1.97	2.84	5.05	7.89	11.36	20.20
	SUSXM7	Tensile	0.48	0.81	1.39	2.03	2.77	4.93	7.71	11.10	19.74
		Shear	0.51	0.91	1.42	2.23	3.21	5.71	8.93	12.86	22.86
	C2700W	Tensile	0.28	0.47	0.81	1.18	1.62	2.88	4.50	6.48	11.53
		Shear	0.31	0.55	0.86	1.35	1.95	3.47	5.42	7.81	13.89
	C1100W	Tensile	0.17	0.29	0.50	0.73	0.99	1.77	2.77	3.99	7.09
		Shear	0.20	0.37	0.58	0.90	1.30	2.32	3.63	5.23	9.30
	A1070W	Tensile	0.07	0.12	0.20	0.28	0.40	0.71	1.16	1.76	2.85
		Shear	0.10	0.18	0.27	0.44	0.60	1.07	1.61	2.25	4.12
	A1200W	Tensile	0.07	0.13	0.20	0.28	0.40	0.71	1.18	1.79	2.88
		Shear	0.11	0.18	0.31	0.46	0.60	1.13	1.74	2.33	4.26
	A5052W	Tensile	0.13	0.23	0.39	0.54	0.74	1.34	2.18	3.15	5.43
		Shear	0.20	0.35	0.56	0.91	1.18	2.21	3.40	4.56	8.32
	A5056W	Tensile	0.17	0.29	0.47	0.60	0.94	1.46	2.61	3.78	6.73
		Shear	0.23	0.40	0.62	1.00	1.30	2.46	3.80	5.20	9.25

Note) Each of the results above is the measured strength of a rivet alone.